

DC and AC Electrical Characterization of Stacks of HTS Tapes

Stefano Ginocchio, Amalia Ballarino, Elena Perini, and Sergio Zannella

Abstract—Today the Bi-2223 tape represents a suitable candidate for the use in various HTS devices. The LHC current leads use Bi-2223 tapes soldered together in short lengths, forming stacks of rugged HTS conductors. Critical current and AC loss measurements were performed on BSCCO stacks, in the temperature range of 65 K and 77 K and in magnetic fields of up to 0.5 T. The experimental results reported in this paper give a broad description of the stacks behavior in the range of current and field values of practical interest, and provide design parameters for the optimization of current leads operating both in DC and pulsed conditions.

Index Terms—AC losses, critical current, current leads, high-temperature superconductors.

I. INTRODUCTION

TODAY long lengths of Bi-2223 tape are commercially available in a quantity and at a performance level allowing their application in many High Temperature Superconducting (HTS) devices [1]. Current leads, used to transfer currents from power converters, working at room temperature, to the liquid helium environment, represent an important application of this emerging technology.

The current leads of the Large Hadron Collider (LHC) use Bi-2223 tapes soldered together, in short lengths (35 cm) to form stacks of rugged HTS conductors [2]. The stacks operate between 50 K and the liquid helium bath. In order to minimize heat conduction, a Ag alloy doped with Au has been chosen for the matrix of the component tapes.

Modelling and design of the current leads require accurate knowledge of the electrical characteristics of the HTS conductors as a function of temperature and magnetic field. In order to evaluate the heat load in transient or pulsed regime, AC loss analysis is also required.

Critical current (I_c) and n -values of some LHC stacks, representative of the two main types integrated in the current leads, were measured in the temperature (T) range 65 K–77 K and in magnetic fields (B) of up to 0.5 T. The resulting $I_c(B, T)$ curves were compared to the corresponding curves of the single tapes.

A sensitive electrical method was used to measure transport AC loss at 60 Hz in tapes and stacks at 77 K. The results were compared with those obtained from Norris formulae [3]. The

Manuscript received August 29, 2006.

S. Ginocchio, E. Perini, and S. Zannella are with Edison S.p.A., Foro Buonaparte, 31, I-20121 Milano, Italy (e-mail: stefano.ginocchio@edison.it).

A. Ballarino is with CERN, European Organization for Nuclear Research, 1211 Geneva 23, Switzerland (e-mail: Amalia.Ballarino@cern.ch).

Color versions of one or more of the figures in this paper are available online at <http://ieeexplore.ieee.org>.

Digital Object Identifier 10.1109/TASC.2007.899137

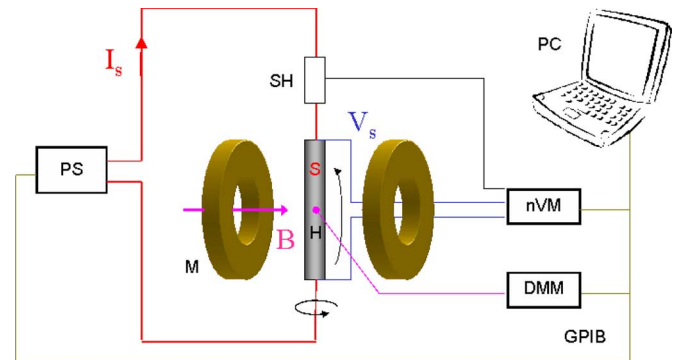

Fig. 1. Sketch of set-up used for critical current vs magnetic field measurements. The sample and the magnet were immersed in the same liquid nitrogen bath.

contribution of eddy current losses at cryogenic temperatures was analysed and is discussed.

II. EXPERIMENTAL METHODS

A. Critical Current vs. Magnetic Field

Critical current measurements were performed according to the four probe method, on the basis of the $1 \mu V/cm$ criterion [4].

The experimental set-up is shown in Fig. 1. The sample (S), soldered to a copper sample holder, was inserted between the two coils of a Helmholtz-type copper magnet (M). Voltage taps were placed in the central part of the sample, where the magnet had the best field homogeneity. A tiny hall probe (H), was placed on the sample holder in the centre of the magnet. This arrangement allowed performing measurements with the surface of the sample either parallel or perpendicular to the magnetic field.

The DC power supply (PS) delivered currents of up to 1500 A; the magnet generated a field of up to 0.5 T. The voltage drop across the sample (V_s) was read via a nanovoltmeter (nVM); the sample current (I_s) was measured by a calibrated resistive shunt (SH). Finally, a digital multimeter (DMM) was used to read the voltage on the hall probe.

The sample and the magnet were immersed in the same vacuum-insulated cryostat filled with saturated liquid nitrogen. The temperature of the nitrogen was lowered down to 65 K by pumping on the bath.

B. Transport AC Losses

Transport AC loss was measured by the electrical method [5].

A scheme of the measurement system is shown in Fig. 2. A DAQ board drove an audio power amplifier (PA) that supplied,

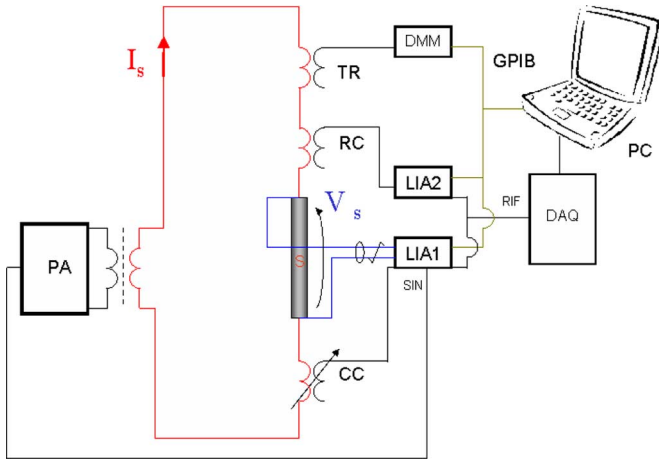

Fig. 2. AC loss measurement system scheme (electrical method). Lock-in amplifiers (LIA) are used to ensure accurate phase detection.

through transformers, AC current to the sample. The current amplitude was measured by the transducer (TR), connected to a digital multimeter (DMM). The DAQ board also provided the reference signal to two lock-in amplifiers: LIA-1 was used to measure the component of the voltage drop across the sample in phase with the transport current, LIA-2 ensured accurate phase setting of current by the Rogowski coil (RC). A variable inductor (CC) compensated for the out of phase component of signals across the voltage taps.

Losses per unit length were evaluated by using the following equation:

$$Q_{transport} = \frac{V_{rms} \cdot I_{rms}}{l \cdot f} \quad (1)$$

where V_{rms} is the in-phase component of the voltage drop across the sample, I_{rms} is the current in the superconductor, f is the frequency (60 Hz in our case) and l is the distance between the voltage contacts.

The AC losses were measured both at liquid nitrogen (from 77 K to 65 K) and liquid helium (4.2 K) temperatures. Voltage taps were placed in the central part of the sample. The voltage leads were wrapped in a figure-of-eight around the sample and twisted in order to minimize the inductive signal due to the sample self-field and the external AC magnetic field.

III. SUPERCONDUCTING SAMPLES

A. Tape Characteristics

The HTS stacks tested within the present work were assembled at CERN from two classes of commercial HTS tapes:

- 1) European High Temperature Superconductors (EHTS). Multi-filamentary Bi-2223 tapes (Ag-Au 5% matrix), cross section: 4.0 mm × 0.22 mm, typical I_c : 70–85 A at 77 K and self-field (s.f.); typical n -value: 30 (date of production: 2005);
- 2) American Superconductor (AMSC). Multi-filamentary Bi-2223 tapes (Ag-Au 5.3 % matrix), cross section: 4.0 mm × 0.215 mm, typical I_c : 100–140 A at 77 K, s.f.; typical n -value: 20 (date of production: 2005).

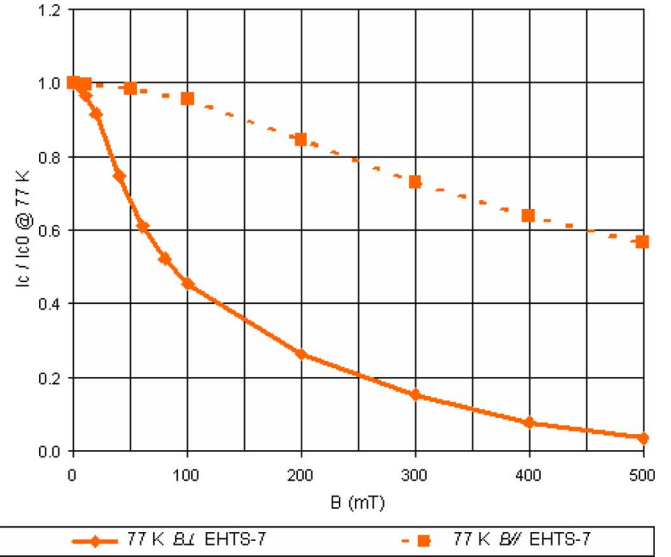

Fig. 3. $I_c(B)$ measurements performed on EHTS-7 stack at 77 K in parallel ($B \parallel$) and perpendicular ($B \perp$) field. Measured I_c values are normalized to I_c at 77 K s.f. (340 A).

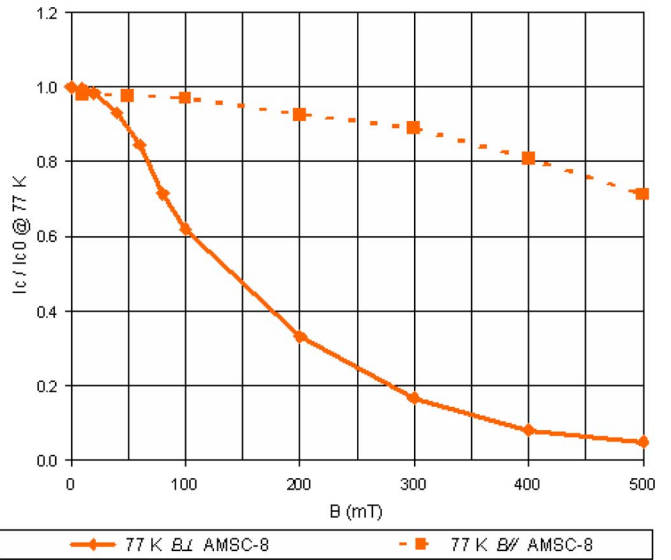

Fig. 4. $I_c(B)$ measurements performed on AMSC-8 stack at 77 K in parallel ($B \parallel$) and perpendicular ($B \perp$) field. Measured I_c values are normalized to I_c at 77 K s.f. (650 A).

B. CERN Stacks for Current Leads

The HTS stacks tested consisted of either 7 or 8 tapes, which were soldered together in vacuum:

- 1) 7 × 76 A EHTS tapes, overall size 4 mm × 1.5 mm × 350 mm (EHTS-7);
- 2) 8 × 124 A AMSC tapes, overall size 4 mm × 1.5 mm × 350 mm (AMSC-8).

IV. MEASUREMENTS AND DISCUSSION

A. $I_c(B)$ Measurements on Stacks

The normalized $I_c(B)$ curves at 77 K of the stacks EHTS-7 and AMSC-8 are reported in Figs. 3 and 4. Their critical currents in self-field conditions (I_{c0}) are respectively 340 A and 650 A.

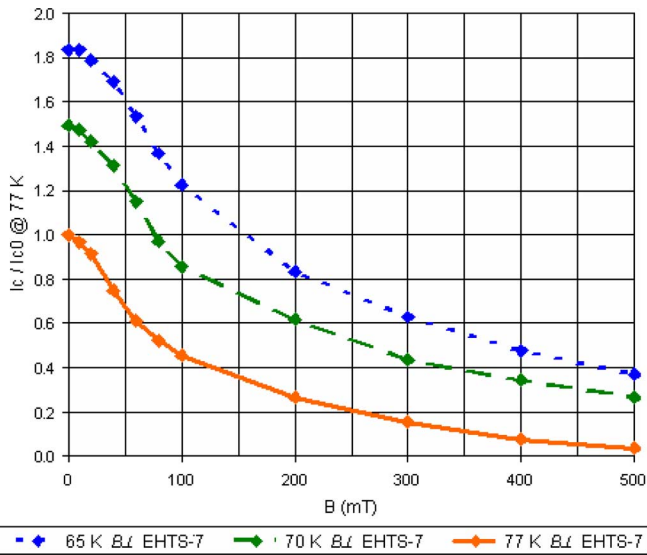

Fig. 5. $I_c(B)$ measurements performed on EHTS-7 stack at 65 K, 70 K and 77 K and in perpendicular field ($B \perp$). Measured I_c values are normalized to I_c at 77 K s.f. (340 A).

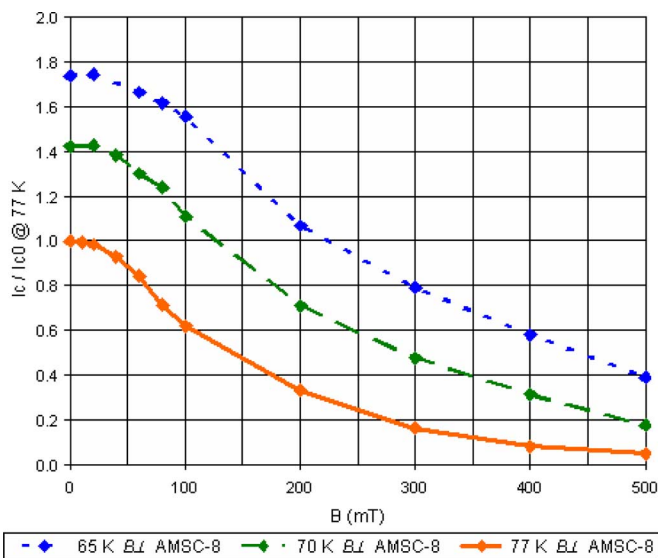

Fig. 6. $I_c(B)$ measurements performed on AMSC-8 stack at 65 K, 70 K and 77 K and in perpendicular field ($B \perp$). Measured I_c values are normalized to I_c at 77 K s.f. (650 A).

The measurements were performed in magnetic field both parallel and perpendicular to the wider surface of the stacks. The normalized $I_c(B)$ curves between 65 K and 77 K are shown in Figs. 5 and 6. In this case, the magnetic field was perpendicular to the wider surface of the tapes (the worst case). Indicative n -values as a function of temperature and magnetic field are summarized in Tables I and II.

The self-field critical current of the stacks was lower than the sum of the I_c of the component tapes by more than 30% [2]; typical n -values of the stacks were also lower than n -values for single tapes. For instance, the I_c of EHTS-7 at 77 K, s.f., was 340 A, while for single tapes one could expect at least $7 \times 76 \text{ A} = 532 \text{ A}$; the I_c of AMSC-8 at 77 K, s.f., was 650 A, while $8 \times 124 \text{ A} = 992 \text{ A}$; the n -value of EHTS-7 at 77 K

TABLE I
 n -VALUES OF EHTS-7 STACK*

Magnetic field B	77 K $B \perp$	77 K $B //$	70 K $B \perp$	65 K $B \perp$
self field	20	20	21	24
100 mT	11	18	12	16
300 mT	4	15	7	9

* n -Values Calculated Between 0.1 and $2 \mu\text{V}/\text{CM}$

TABLE II
 n -VALUES OF AMSC-8 STACK*

Magnetic field B	77 K $B \perp$	77 K $B //$	70 K $B \perp$	65 K $B \perp$
self field	20	20	22	26
100 mT	13	20	14	21
300 mT	4	19	7	11

* n -Values Calculated Between 0.1 and $2 \mu\text{V}/\text{CM}$

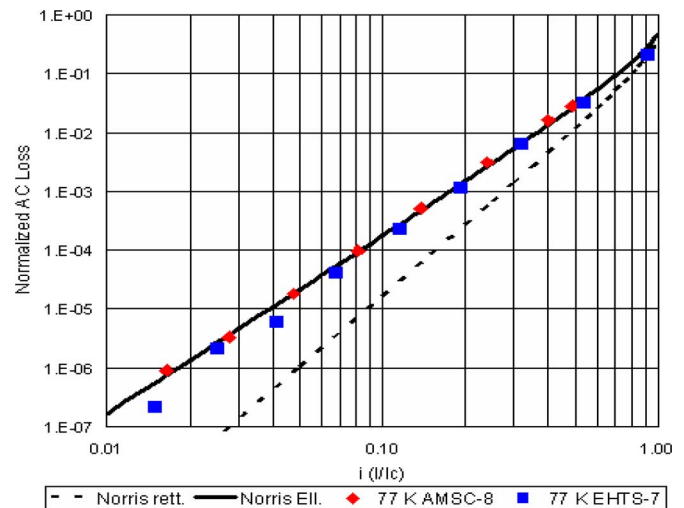

Fig. 7. Transport AC loss measurements performed on EHTS-7 and on AMSC-8 stacks at 77 K compared with Norris losses. Measured losses (W/m) are normalized to $f\mu_0 I_c^2/\pi$.

s.f. was 20 while values of 30 were achieved in EHTS single tapes. The self-field I_c reduction could be explained taking into account the increased self-field of the stacked conductor with respect to the single tape [2]; as a consequence the stacks exhibited a better $I_c(B, T)/I_c(0 \text{ T}, 77 \text{ K})$ ratio in external field. The measurements indicated that the stacks still exhibited an $I_c(B)/I_c(0 \text{ T}, 77 \text{ K})$ ratio higher than 0.6 at 65 K in fields of up to 300 mT, while the ratio for tapes was measured to be 0.4.

It is important to minimize the perpendicular component of the field in the final assembly, as is evident from the $I_c(B)$ curves in Figs. 36. Also, the gain in I_c in self-field conditions was about 1.8 from 77 K to 65 K, and it became even higher (up to a factor of three) in the presence of magnetic field.

B. AC Loss Measurements on Stacks

The AC loss measurements performed on EHTS-7 and AMSC-8 stacks at 77 K and 60 Hz are reported in Fig. 7. For

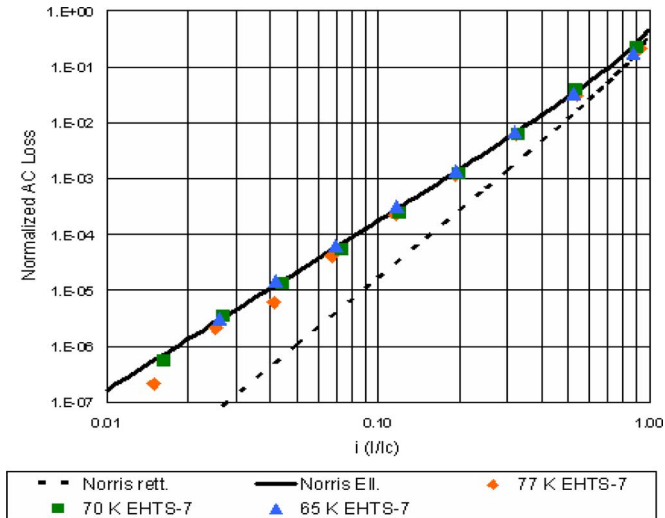

Fig. 8. Transport AC loss measurements performed on EHTS-7 stacks at 65, 70 and 77 K compared with Norris losses. Measured losses (W/m) are normalized to $f\mu_0 I_c^2 / \pi$.

TABLE III
HYSTERESIS AND EDDY CURRENT AC LOSSES*

Stack	I_c at 77 K (A)	hysteresis at 77 K (mW/m)	eddy curr. at 77 K (mW/m)	eddy curr. at 20 K (mW/m)
EHTS-7	340	78	0.011	0.028
AMSC-8	640	282	0.039	0.098

*Calculated at $0.5 I_c$, S.F., 60 HZ

the EHTS-7 stack, the measurements performed at 65 K, 70 K, and 77 K are compared in Fig. 8.

Self-field transport losses of the stacks at 60 Hz agreed excellently with Norris formulae for the elliptical model [3], that describes well the behaviour of the single tapes due to pure hysteresis [5]. This means that the losses in the stacks were dominated by hysteresis at liquid nitrogen temperatures.

In the current leads, the HTS operates in a range of temperature from slightly below 77 K down to 4.2 K. According to Norris formulae it is expected that the main contribution to the transport losses is generated at the warm end of the stack, due to its lower I_c . The contribution of the eddy current losses was estimated for stacks operating at 77 K and 20 K. They corresponded to less than 0.1 % of the hysteresis losses calculated at 77 K, as shown in Table III.

V. CONCLUSION

The experimental results give a broad description of the Bi-2223 stack behavior in the range of current and field of practical interest, and provide design parameters for the optimization of the HTS part of current leads operating both in DC and pulsed conditions.

In particular, the $I_c(B)$ curves provide the basic engineering parameters for DC current lead design. HTS stacks exhibited a total self-field critical current about 30% lower than the sum of the I_c of component tapes, and a lower n -value (20) than single tapes (20–30). However, they exhibited a smaller degradation of the overall stack I_c in external magnetic fields, more evident in the case of fields perpendicular to the wider surface of the stacks.

60 Hz AC losses in the stacks obeyed the same hysteresis law that describes well the behaviour of the single tapes. Eddy current losses in the matrix were negligible. It is thus confirmed that current leads using stacks of Bi-2223 tapes with Ag-Au matrix are efficient both for DC and low frequency AC operation.

ACKNOWLEDGMENT

The authors thank Dr. Serge Mathot for the preparation of the vacuum soldered samples and Lionel Poyet for the realization of the necessary tooling.

REFERENCES

- [1] A. Ballarino, "Application of high temperature superconductors to accelerators," in *Proceedings of EPAC 2000*, Vienna, Austria [Online]. Available: http://at-mel-cf.web.cern.ch/at-mel-cf/resources/HTS_for_Accelerators_PAC.pdf, LHC Project Report 420
- [2] A. Ballarino, L. Martini, S. Mathot, T. Taylor, and R. Brambilla, Large Scale Assembly and Characterization of Bi-2223 HTS Conductors submitted for publication at this conference.
- [3] W. T. Norris, "Calculation of hysteresis losses in hard superconductors carrying ac: Isolated conductors and edges of thin sheets," *Journal of Physics D: Appl. Phys.* vol. 3, pp. 489–507, 1970 [Online]. Available: <http://www.iop.org/EJ/journal/JPhysD>
- [4] International Electrotechnical Commission, IEC-61788-3, (international standard for I_c measurement), 2000.
- [5] S. Zannella, L. Montelatici, G. Greci, M. Pojer, L. Jansak, M. Majoros, G. Coletta, R. Mele, R. Tebano, and F. Zanovello, "AC losses in transport current regime in applied AC magnetic field: Experimental analysis and modeling," *IEEE Trans. Appl. Supercond.*, vol. 11, no. 1, pp. 2441–2444, March 2001.